

10K Gate Valve

10SMBOF
B.B.O.S.Y.
FF-flanged

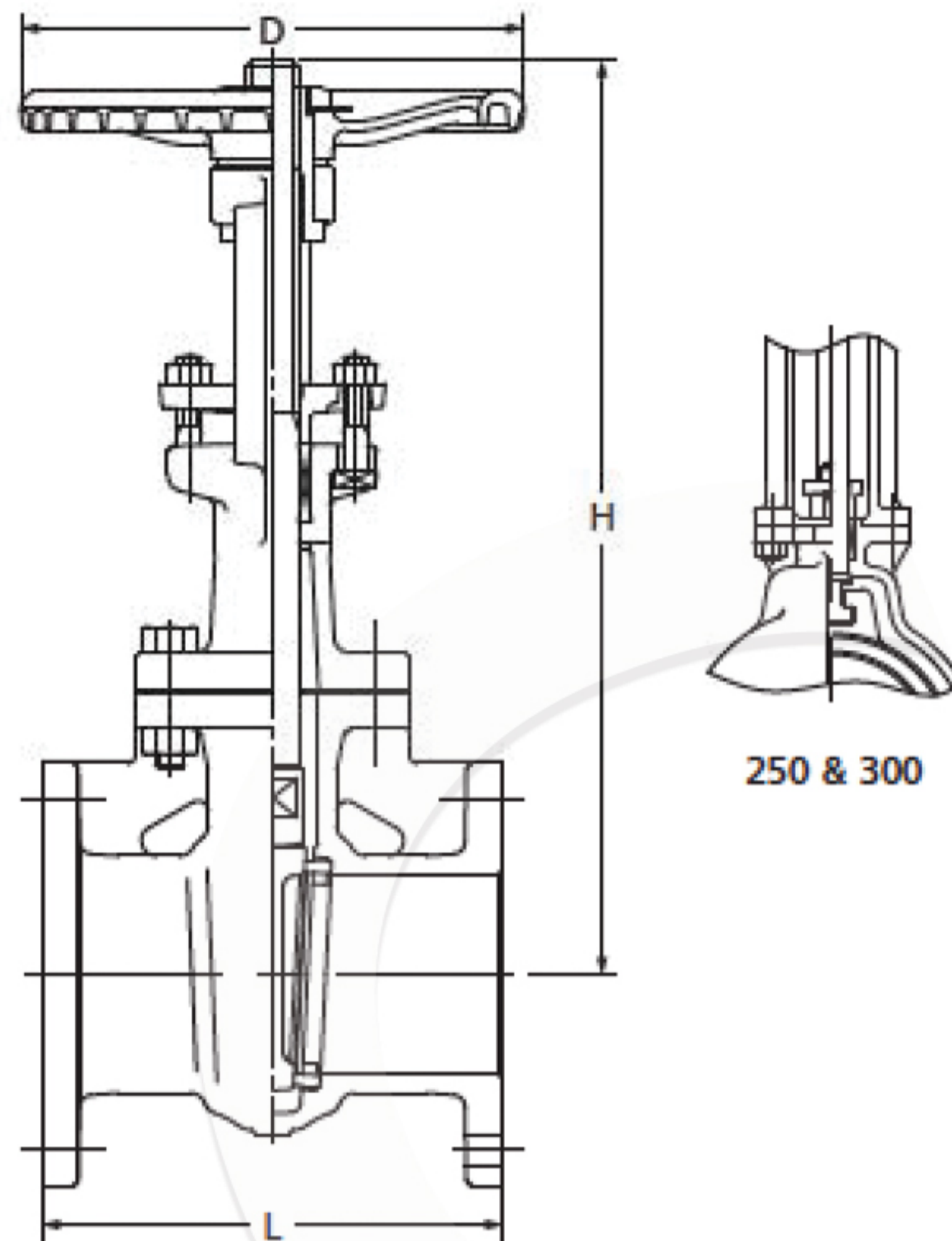
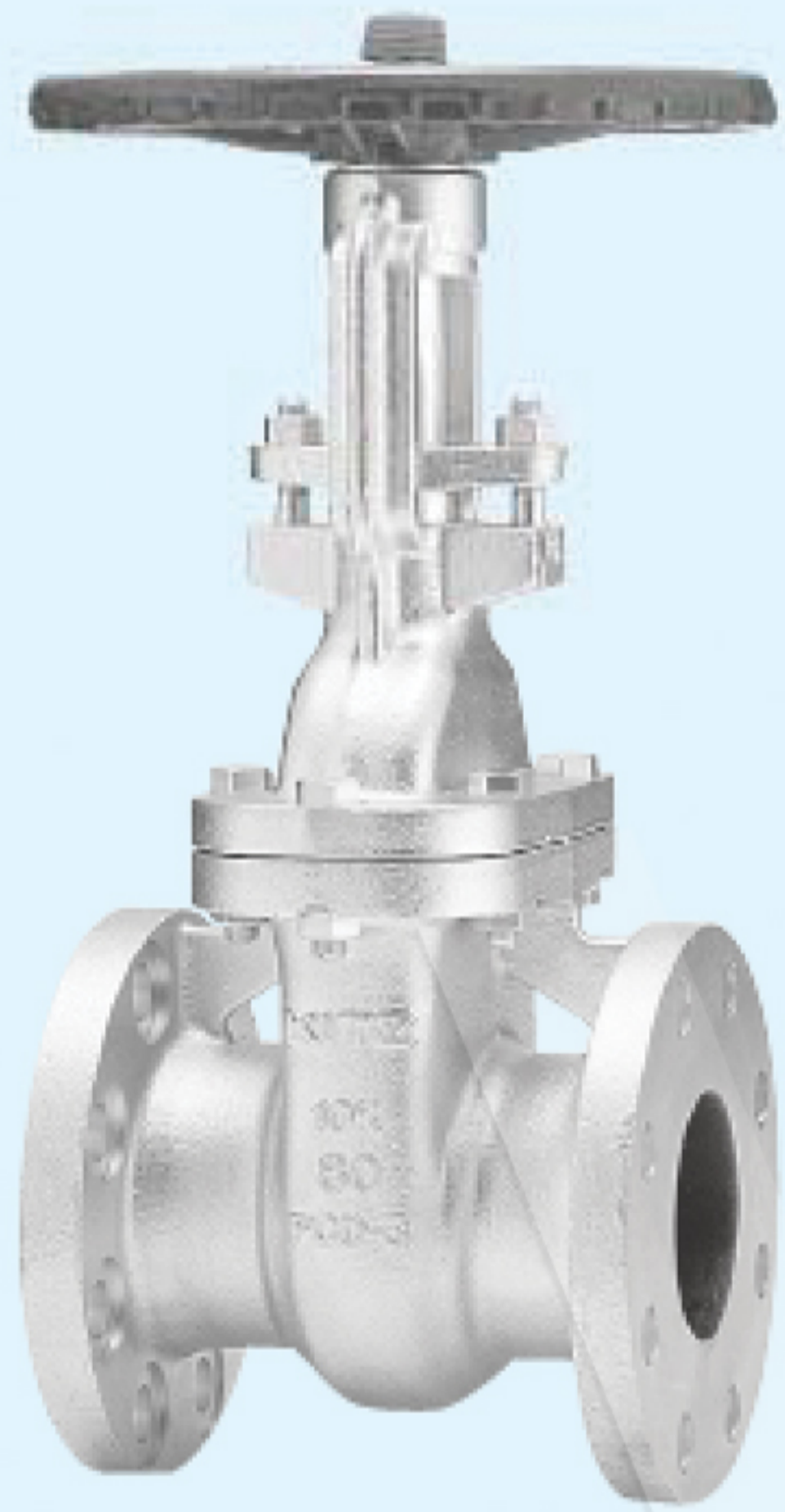

Face to face : JIS B 2002
End connection : JIS B 2239 10K

120°C Static water..... 1.4MPa
220°C Steam, air, gas, oil..... 1.2MPa
300°C Steam, air, gas, oil..... 1.0MPa

- Use for lubricating or hydraulic oil is acceptable. Contact KITZ Corporation for technical advice, if valves are used as heat transfer media.
- Bolting materials will be changed for servicing high temperature exceeding 225°C. Contact KITZ Corporation for detailed information.

Materials

Parts	JIS material
Body	FCD-S
Bonnet	FCD-S
Stem	SUS403
Disc	SUS403 / SCS1 (40~200) A105 + 13Cr (250) SCPH2 + 13Cr (300~500)
Body seat ring	SUS403
Gland	FCD-S (400 & 500:SUS403)
Gland packing	Non-asbestos Packing (50~300) Flexible Graphite Braided Packing (350~500)
Handwheel	FCD400 (40~300) FCD400-15 (350~500)
Bonnet bolt/nut	Carbon Steel
Gland bolt/nut	Carbon Steel
Yoke sleeve	C6782BE(40~150) CAC302(200~300) CAC406(350 & 450) Ductile Ni-resist(400 & 500)
Yoke	FCD-S
Gasket	Stainless Foil Inserted Flexible Graphite
Name plate	A1050P

Dimensions

Size	mm														
	mm	40	50	65	80	100	125	150	200	250	300	350	400	450	500
	inch	1½	2	2½	3	4	5	6	8	10	12	14	16	18	20
L		165	178	190	203	229	254	267	292	330	356	381	406	432	457
H (open)		300	352	410	479	566	667	779	969	1181	1404	1538	1702	1538	1702
D		160	200	200	250	250	300	300	350	400	450	500	600	500	600

NOTE : For flange dimensions, refer to Page 44. ※RF-flanged ends shall be optionally available.